

Single Jet Dry Dial Vane Wheel Water Meter

Model: LXSC-13D8S



APPLICATION:

- ◆ Measuring the volume of cold potable water passing through the pipeline.

FEATURES:

- ◆ Single jet, dry dial;
- ◆ Magnetic drive, magnet resistance;
- ◆ Optimum accuracy and performance at all times;
- ◆ Accurate measurement, easy and long term clear reading, etc.

WORKING CONDITION:

- ◆ Water temperature: Cold Water Meter $\leq 40^{\circ}\text{C}$ Hot Water Meter $\leq 90^{\circ}\text{C}$
- ◆ Water pressure: $\leq 1.6\text{Mpa}$ (16bar)

MAXIMUM PERMISSIBLE ERROR:

- ◆ In the lower zone from q_{\min} inclusive up to but excluding q_t is $\pm 5\%$
- ◆ In the upper zone from q_t inclusive up to and including q_s is $\pm 2\%$

Type	Size (mm)	Class	q_s	q_p	q_t	q_{\min}	Min. Reading	Max. Reading
			Max. Flow	Nominal Flow	Transitional Flow	Min. Flow		
			m^3/h		L/h		m^3	
LXSC-13D8S	15	B	3	1.5	120	30	0.0001	99999
		C			22.5	15		

Type	Size	L	B	B	Connection Thread	Weight
LXSC-13D8	15	115	77	85	G3/4B	0.45kg

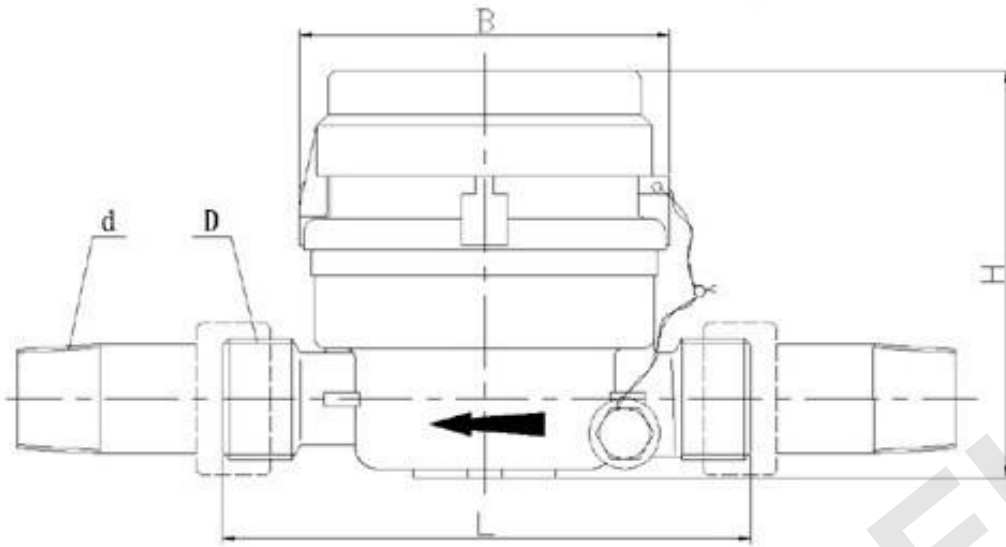

性能误差曲线

Flow Error Curve

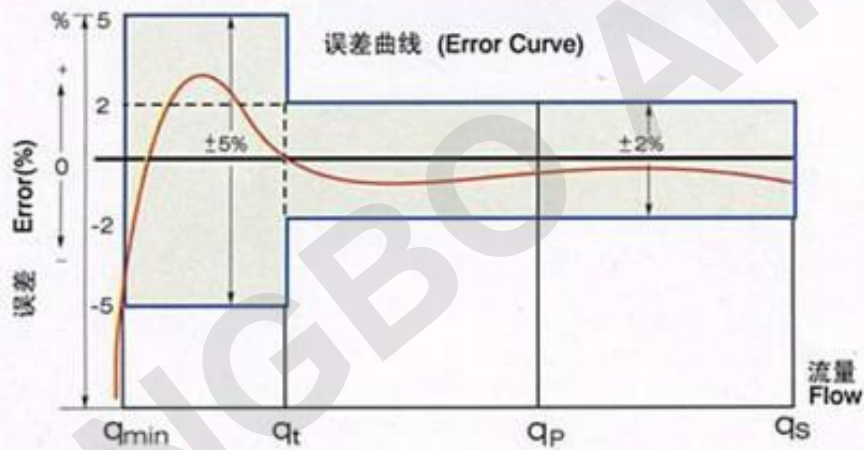

水头损失曲线

Pressure Loss Curve

